

YOUR SAFETY IS OUR PRIORITY

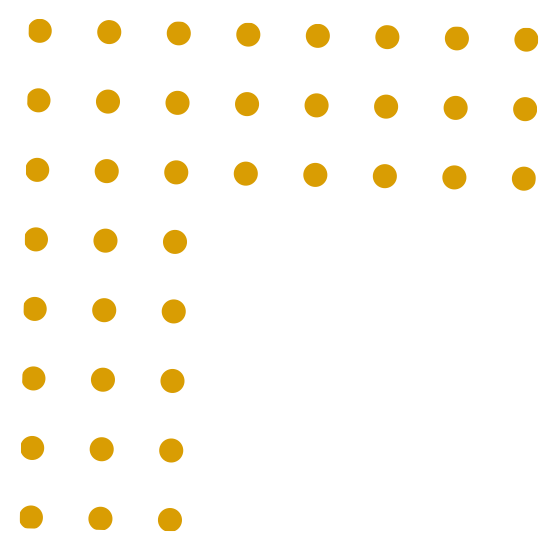

Fire Hydrant/Alarm/Suppression System ◀

Surveillance System ◀

Smart Lighting System ◀

Automatic Gates + Turnstiles ◀

Access Control System ◀

Home Security System ◀

Metal Detector ◀

PA & EPBAX ◀



+91 9915222897



www.abrolgroup.com



sales@abrolgroup.com

**ABROL
ENTERPRISES**

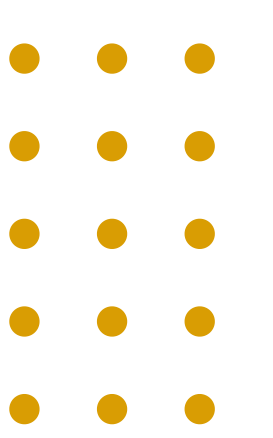

FIRE HYDRANT SYSTEM

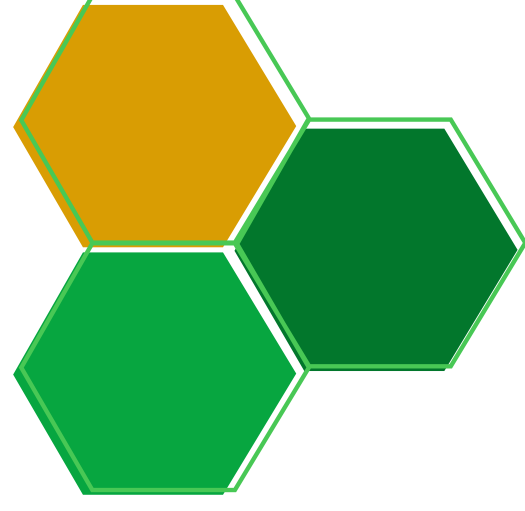

We offer a wide array of premium quality automatic fire hydrant & sprinkler systems. These systems are precision engineered and fabricated using high grade material to ensure durability and quality



FIRE HYDRANT & SPRINKLER SYSTEM PRODUCT COMPONENTS:

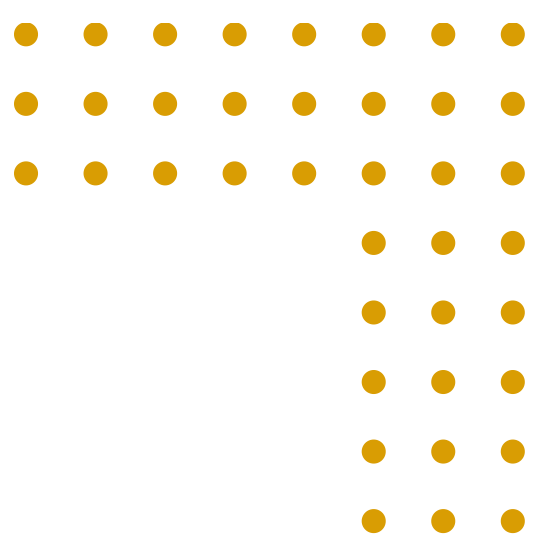

Hydrant Valve:

- a. Single Headed Hydrant Valve 63 mm dia. With ISI mark.
- b. Double Headed Hydrant Valve 63 mm dia. With ISI mark

Hose Reel Drum with Hose and Nozzle: Fire Hose Reel Drums are wall mounted type and can suit 30mtr of 19mm dia. rubber hose with nozzle and have a rolling capacity of 30 mtrs. Fabricated using natural or synthetic rubber, highly dependable and durable.

Fire Fighting Hose:

- a. Percolating fire fighting hose having inside special rubber coating in 15 Meters length with Stainless Steel Male & Female Couplings binded with copper wire.
- b. 63 mm internal Dia. brand non percolating Fire Fighting hose bearing ISI mark quality systems in length of 15 meters.

Branch Pipe:

Branch Pipe Gun Metal 63 mm dia. male instantaneous inlet and male threaded outlet complete with hexagonal base bore Nozzles with ISI Mark.



Hose Box:

MS Hose Box Double Door Size: 24" x 30" x 10" are fabricated from high quality made from thick plate mild steel with glass door fram per ISI Specification.

Fire Brigade Inlet:

- a. Two way Fire Brigade inlet
- b. Three way Fire Brigade inlet
- c. Four way Fire brigade inlet

Gun Metal Coupling: Gun Metal Male & Female Coupling 63mm Dia with ISI mark.

Upright and Pendent Sprinkler: The Upright and Pendent Sprinklers are automatic sprinklers of the frangible bulb type. They are intended for use in fire sprinkler systems designed in accordance with the standard installation rules recognized by the applicable Listing or Approval agency. The Upright, Pendent Sprinklers all produce a hemispherical water distribution pattern below the deflector.

Yard Hydrant: Yard Hydrant with Single Headed Hyfrant Valve 63 mm dia with ISI mark

POWDER EXTINGUISHERS ABC STORED PRESSURE TYPE



Ideal Use

Home Office Building Warehouses Factories Electrical Equipments Rooms | Welding Areas etc

ITEM CODE	FG000048	FG000049	FG000050	FG000051	FG000052
Capacity	1Kg	2Kg	4Kg	6Kg	9Kg
Fire Rating	1A:8B	1A:13B	2A:21B	3A:34B	4A:89B
Height (Approx)	325mm	380mm	490mm	530mm	575mm
Diameter (Approx)	86±10mm	106±10mm	140±10mm	150±10mm	180±10mm
Average Discharge Time	9Sec	14Sec	18Sec	24Sec	31Sec
Average Range of Throw	2m	2.5m	3m	5m	6m
Average % Discharge	92%	92%	94%	93%	93%
Operating Temperature	-20 to +55 °C	-20 to +55 °C	-20 to +55 °C	-20 to +55 °C	-20 to +55 °C
Max service pressure	17Bar	17Bar	17Bar	17Bar	17Bar
Test Pressure	35 Bar	35 Bar	35 Bar	35 Bar	35 Bar
Expelling Agent	Nitrogen	Nitrogen	Nitrogen	Nitrogen	Nitrogen
Shipping Weight (Approx)	2.1 Kg	3.6 Kg	7.0 Kg	9.2 Kg	13.6 Kg
Approvals	BIS & CE	BIS & CE	BIS & CE	BIS & CE	BIS & CE



MODULAR AUTOMATIC ABC TYPE FIRE EXTINGUISHERS

SIZES	ITEM CODE	PROPELLENT	AREA PROTECTION	VOLUME PROTECTION	HANGING VERTICALLY ABOVE RISK	OPERATION TIME IN SECONDS
2Kgs	FG000059	Nitrogen	1 to 1.5 m ²	3m ³	1.5	6-8
5Kgs	FG000056	Nitrogen	2 to 2.5m ²	7m ³	1.5m to 2m	8-10
10Kgs	FG000060	Nitrogen	4 to 5m ²	12m ³	1.75m to 2.25m	10-15
15Kgs	FG000061	Nitrogen	5 to 6m ²	17m ³	2m to 3m	15-20



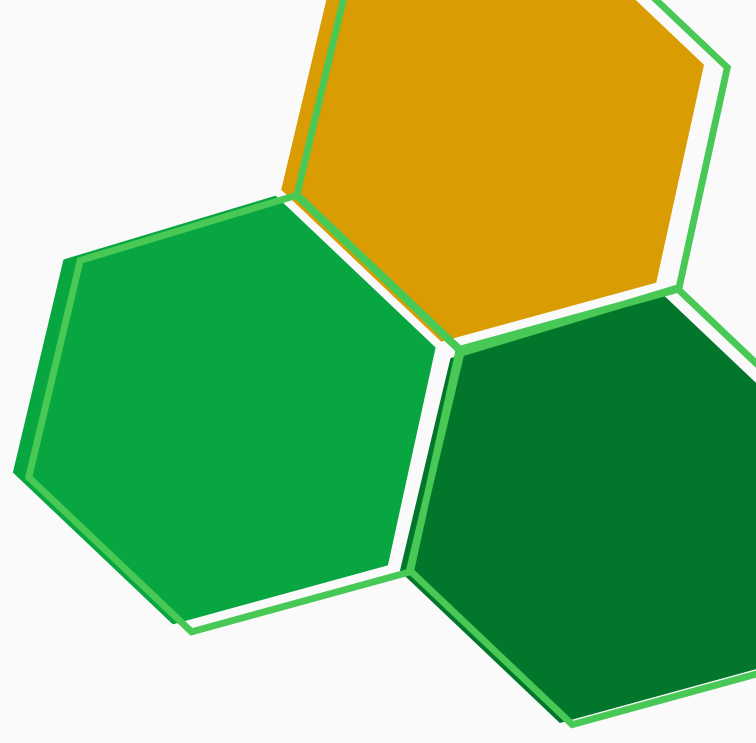

ADVANTAGES

- This system can be installed directly to any environment on ceiling without any drastic modification in structures
- Since the system is installed on ceiling it is unobstructive to man & material & it contains approximately no space on floor
- It can be installed to any site which is impracticable for future suppression or flooding system installation
- Cost-effective, No any bulk installation & flexible.
- As in flooding system this system doesn't require any extra room / floor for storage of extinguishing agent containers
- 24x7 protection & programmed operation



COMPONENTS

- Rated capacity extinguisher with solenoid operative valve
- Smoke detector
- Heat detector
- Master control panel
- Manual Release (or Abort) switch
- Hooter with strobe light
- Relay module

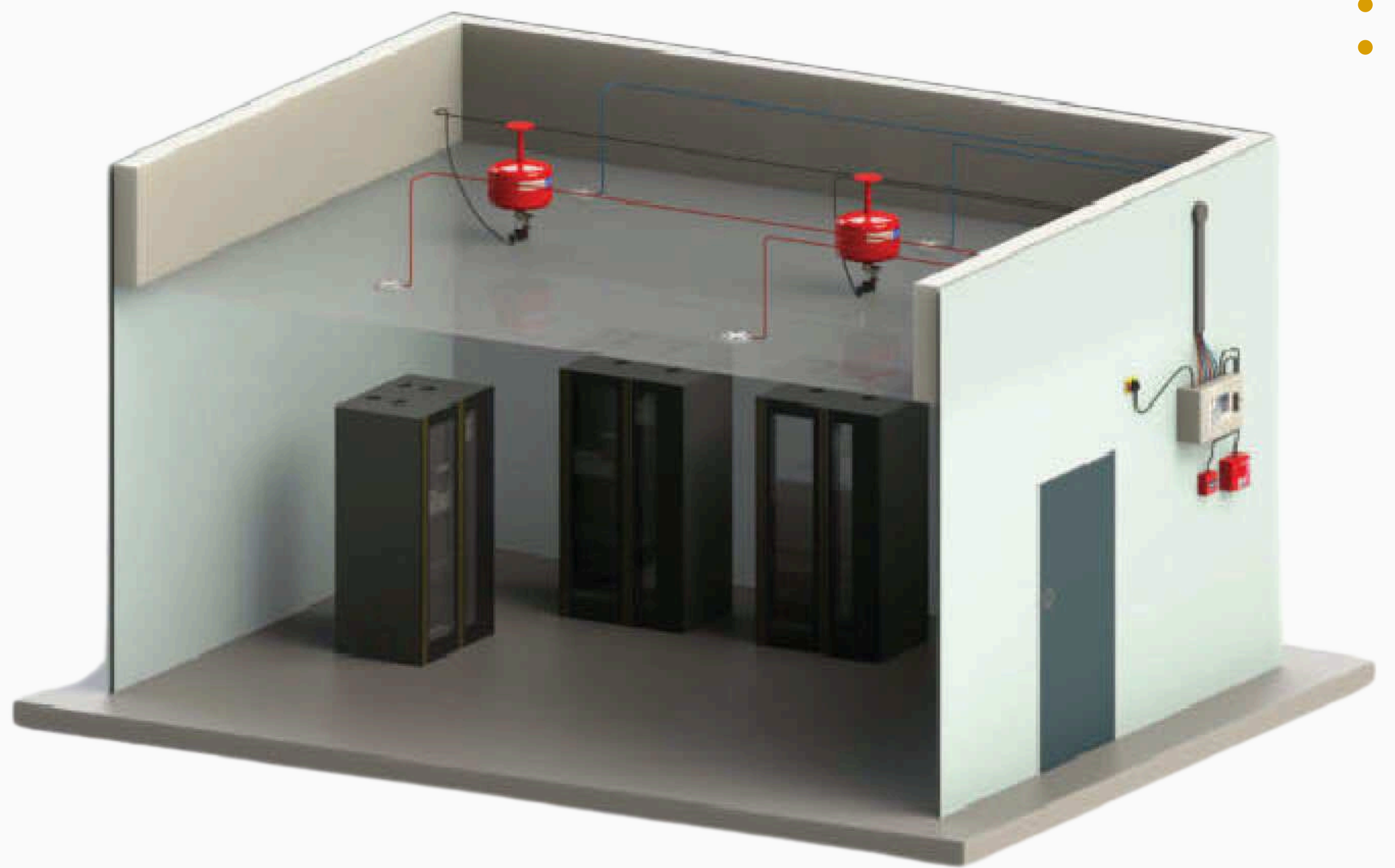

PERFORMANCE DATA

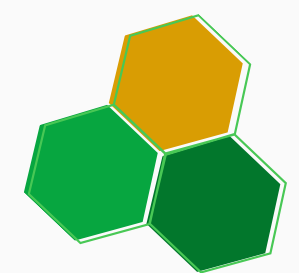

	A	B	C	D	E	F	G	H
Content (Agent)	Clean agent (HFC 236fa / FE 36 / HFC 227ea / FM 200)				MAP-50% / MAP-90% / MAP-90% UL Listed Powder			
Capacity	2 kg	5 kg	10 kg	15 kg	2 kg	5 kg	10 kg	15 kg
Design	Ceiling Mounted							
Dimensional Height (Approx)	380 mm	375 mm	405 mm	425 mm	380 mm	375 mm	405 mm	425 mm
Diameter (Approx)	150 +- 10 mm	230 +- 10 mm	300 +- 10 mm	400 +- 10 mm	150 +- 10 mm	230 +- 10 mm	300 +- 10 mm	400 +- 10 mm
Average Discharge time	4-5 Sec	6-8 Sec	10-15 Sec	15-20 Sec	4-5 Sec	6-8 Sec	10-15 Sec	15-20 Sec
Floor to nozzle Height	1.5 Mtr	2.0 Mtr	2.0 Mtr	2.5 Mtr	1.5 Mtr	2.0 Mtr	2.0 Mtr	2.5 Mtr
Average % Discharge	99%	99%	99%	99%	99%	99%	99%	99%
Operating Temperature	-30 °C to +60 °C							
Service / Test Pressure	15 / 35 bar							
Expelling Agent	Nitrogen (UHP grade)							
Empty / Full. [Weight (Approx.)]	1.56 / 3.56 kg	2.64 / 7.64 kg	4.11 / 14.11 kg	6.4 / 21.4 kg	1.56 / 3.56 kg	2.64 / 7.64 kg	4.11 / 14.11 kg	6.4 / 21.4 kg
Mounting Bracket	Ceiling mounting stand							



TOTAL FLOODING SYSTEM

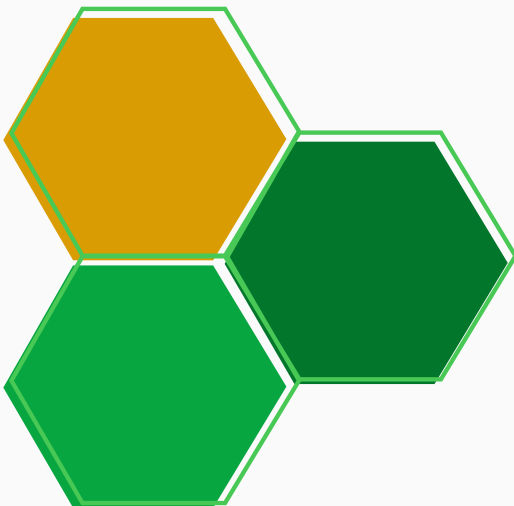

ABR total flooding system is a fixed suppression system which is arranged to automatically discharge a predetermined concentration of agent into an enclosed space for the purpose of fire extinguishment or control. Each system is custom engineered to quickly suppress fires while eliminating agent cleanup and minimizing the downtime that can be associated with other agent types.



Data centres

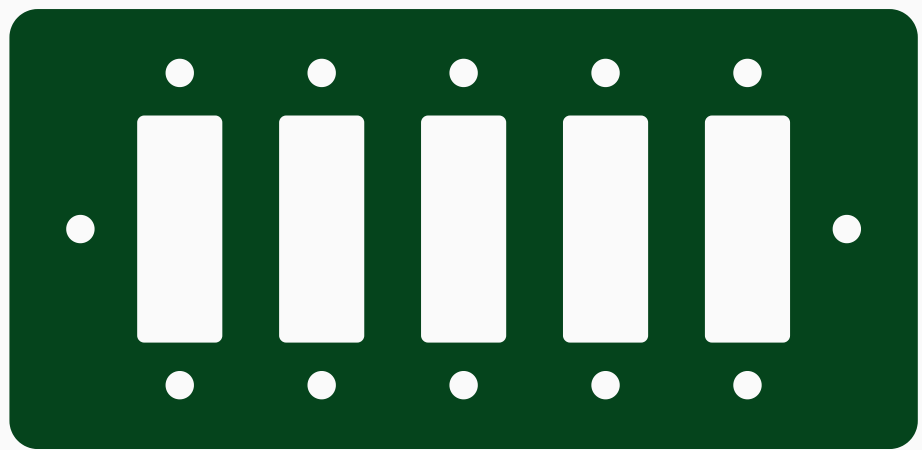

Electrical Switching Rooms

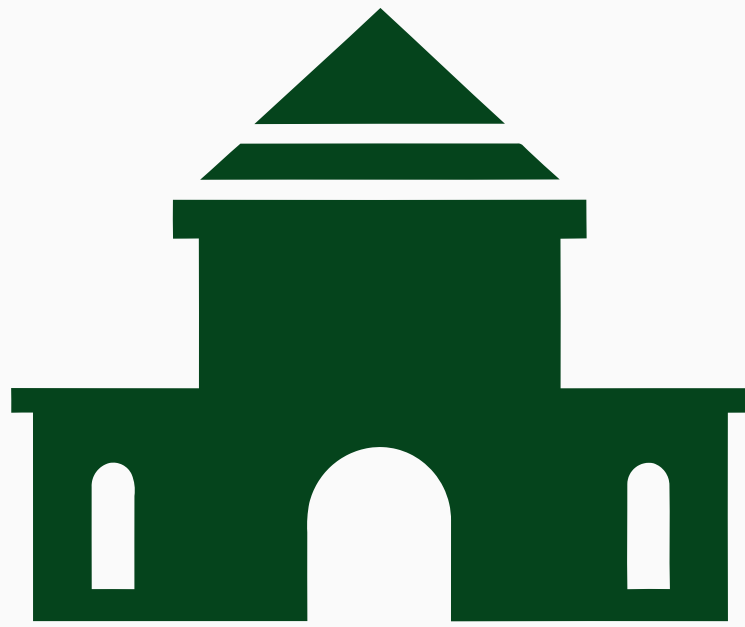

Heritage Sites

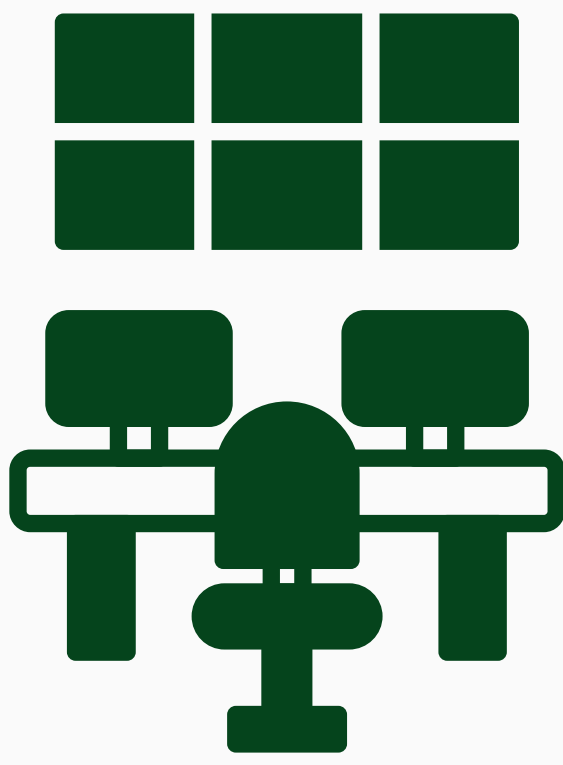

Electrical control rooms

FEATURES

- Safe for electrical/electronic equipment.
- Environmental Friendliness
- 24X7 protection with design Flexibility
- Zero or minimum Downtime/Cleanup
- Wide acceptance

ABR SERVICES:

- Analysis of fire hazard
- System design and support
- Installation and service

WHAT ARE THE VARIOUS TYPES OF FIRE SUPPRESSION SYSTEMS AVAILABLE TODAY?

Chemical Clean Agent gases Include 3M Novec-1230 (FK 5112), FM-200 (HFC-227ea), Fire Protection Fluid and others, all of which offer fast-acting, and most importantly, people-safe fire-suppressing solutions.

In the current scenario/field of fire suppression, Novec-1230 (Generic name: FK 5112) gas is the most recent generation of gas-based chemical extinguishing systems, with a variety of distinctive features and benefits. Novec-1230 is based on a long-term, sustainable technology with one of the highest safety margins and offers swift and reliable extinguishment with minimal environmental impact, particularly on global warming.

It works by completely flooding the area, and extinguishing the flames in a matter of seconds. It is appropriate for the dangers of classes A, B, and C. ABR extinguishing system is completely tailored to the unique features of the agent, resulting in the most dependable and cost-effective solutions.

Inert Gases - Include nitrogen, argon and CO₂, or a combination of two or more, and reduce oxygen levels to a point where combustion cannot be sustained.

Co₂ Systems - Provide a heavy blanket of gas that reduces the oxygen level to a point where combustion cannot occur.

The system is designed as per NFPA standard.

CERTIFICATION

Certifications available Vds/FM/UL (as per Client Requirement)

Fire Alarm

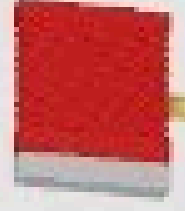

Manual Valve

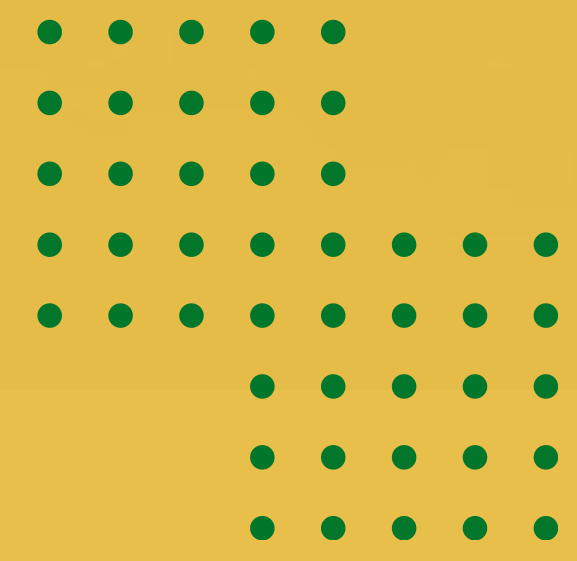
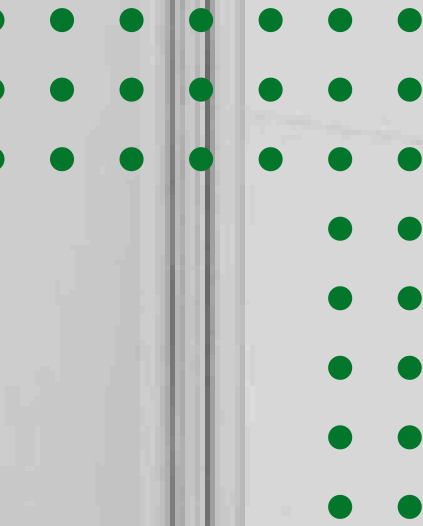

TUBE BASED SUPPRESSION SYSTEM



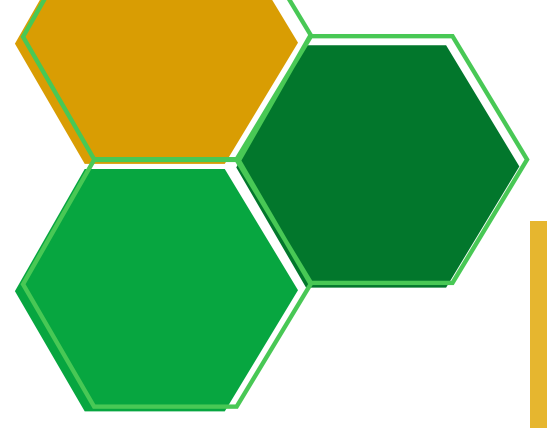

The Tube type extinguishing system has been specifically designed for use in catering/commercial kitchens. The fire detection elements respond the moment the first small flame occurs, and the fire is promptly extinguished before serious damage can occur. This system works in two ways, it is sprayed through fine nozzles onto the equipment forming a blocking layer over the fat or oil so that the fire is starved of oxygen. Simultaneously, the fat is cooled down by the water contained in the agent, so preventing self-ignition. Thus this system as effective and reliable a Conventional extinguishers. Preventing renewed self-ignition

FEATURES

- Flexible protection
- Safety
- The pneumatic triggering
- Minimizes service stoppage during repairs
- Help prevent personnel injury



LPS 1223:Issue 2.3
Cert.No. 724b

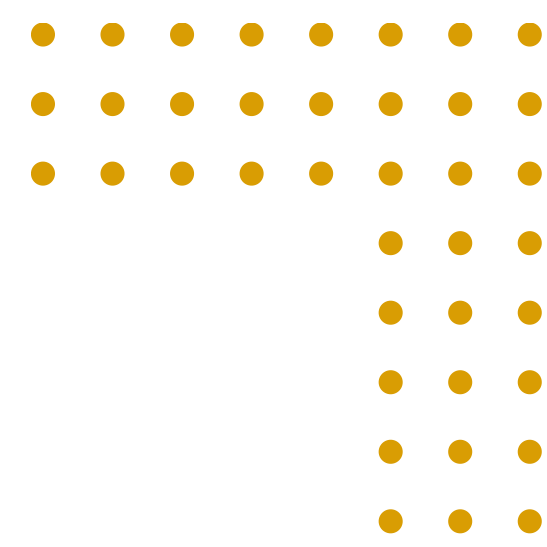

SPECIFICATION

LINE DIAGRAM

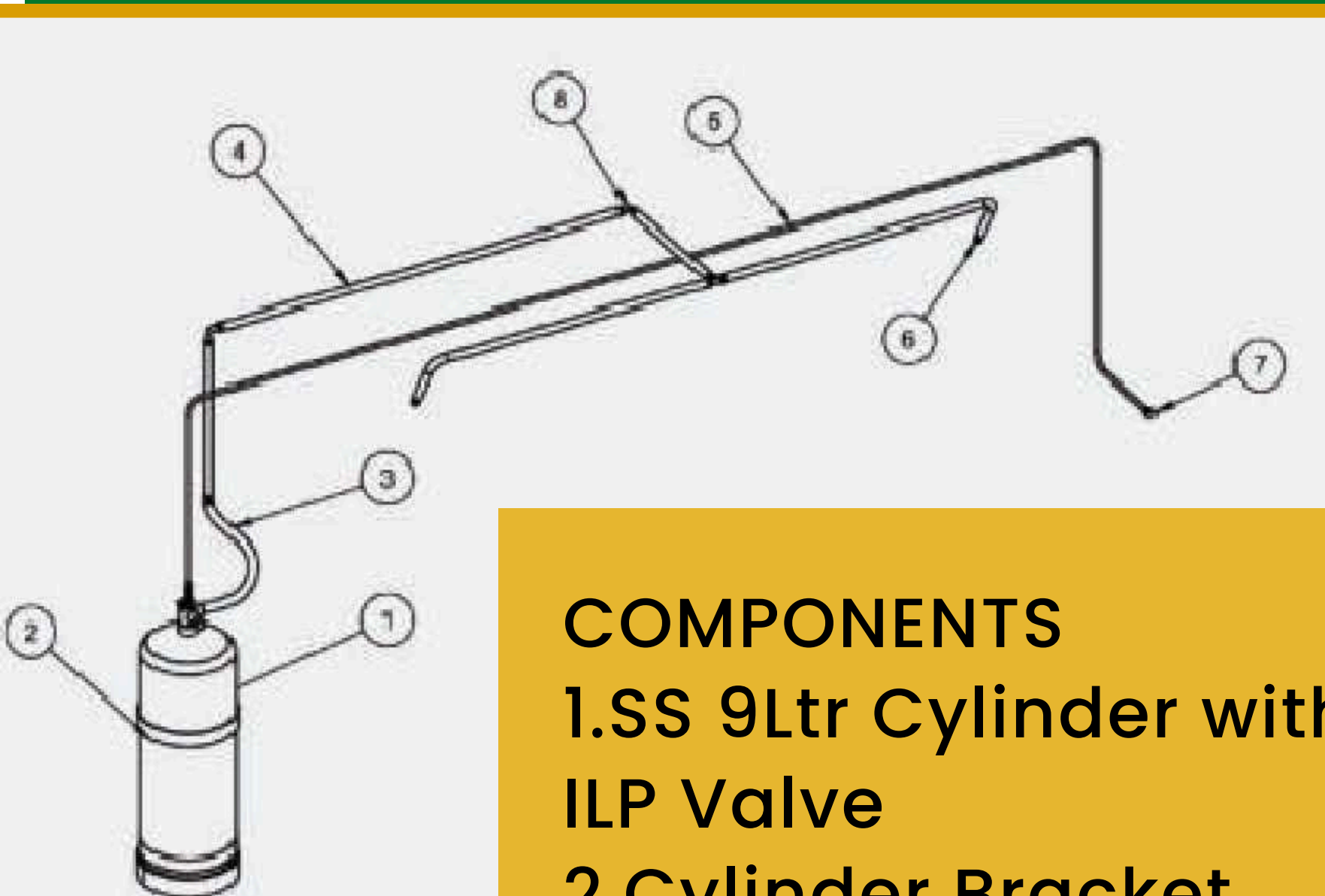

- COMPONENTS**
- 1.SS 9Ltr Cylinder with ILP Valve
 - 2.Cylinder Bracket
 - 3.Discharge Hose
 - 4.5S Discharge Tube
 - 5.Heat Sensing Tube
 6. Discharge Nozzle
 - 7.Manual Release

Extinguishing Agent	Class F
Propellant	Nitrogen
Volume of Extinguishing Agent	9 Ltr
Tube Pressure	16 Bar
Burst Temperature	175°C
Cylinder Pressure	16 Bar
Working Temperature	-20° C to +50°C
Cylinder Volume	12 Ltr
Weight	13 KG



FIRE ALARM SYSTEM

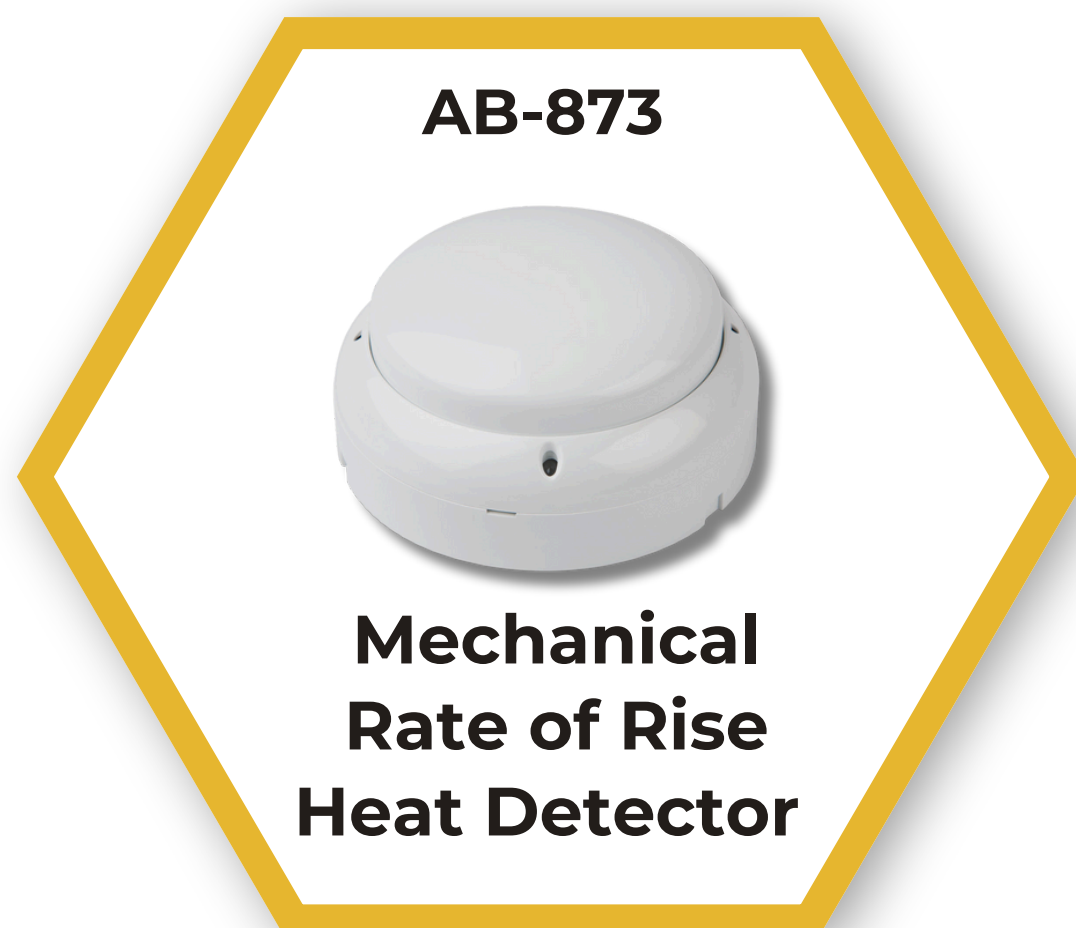
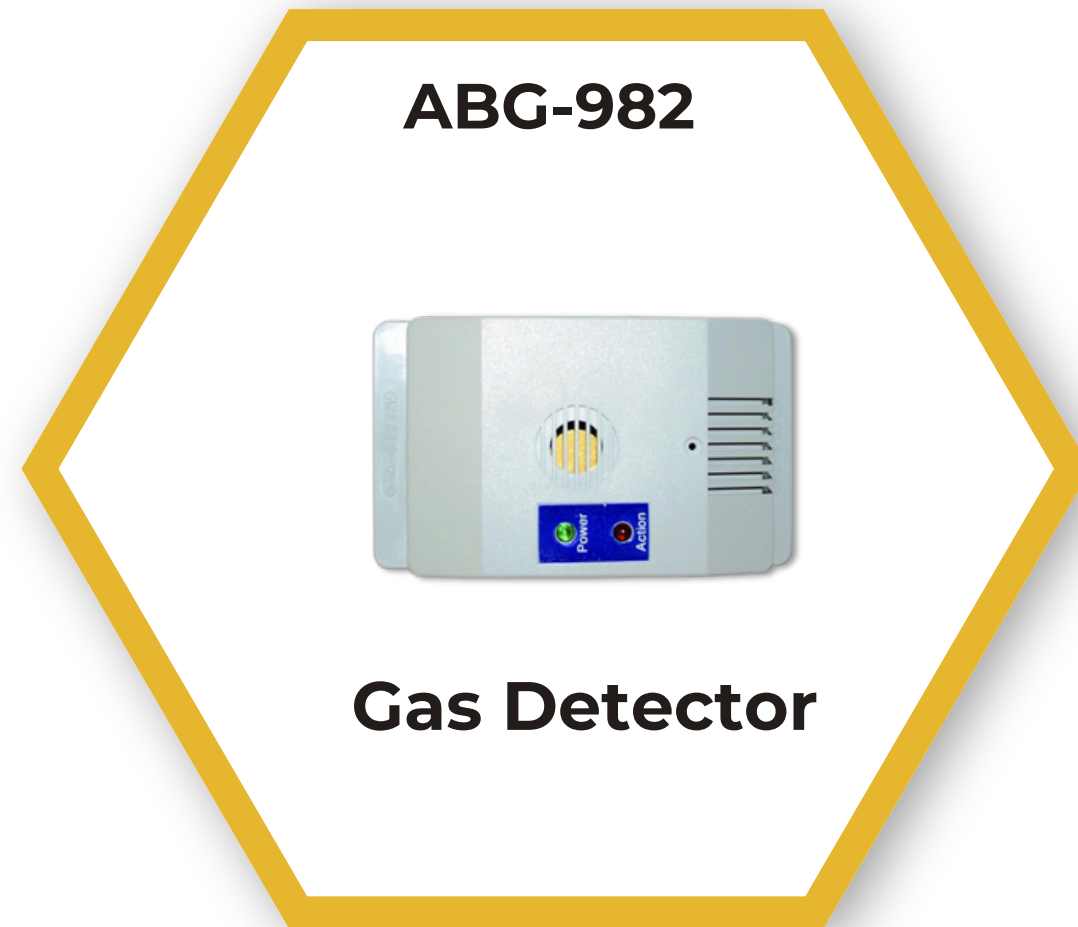
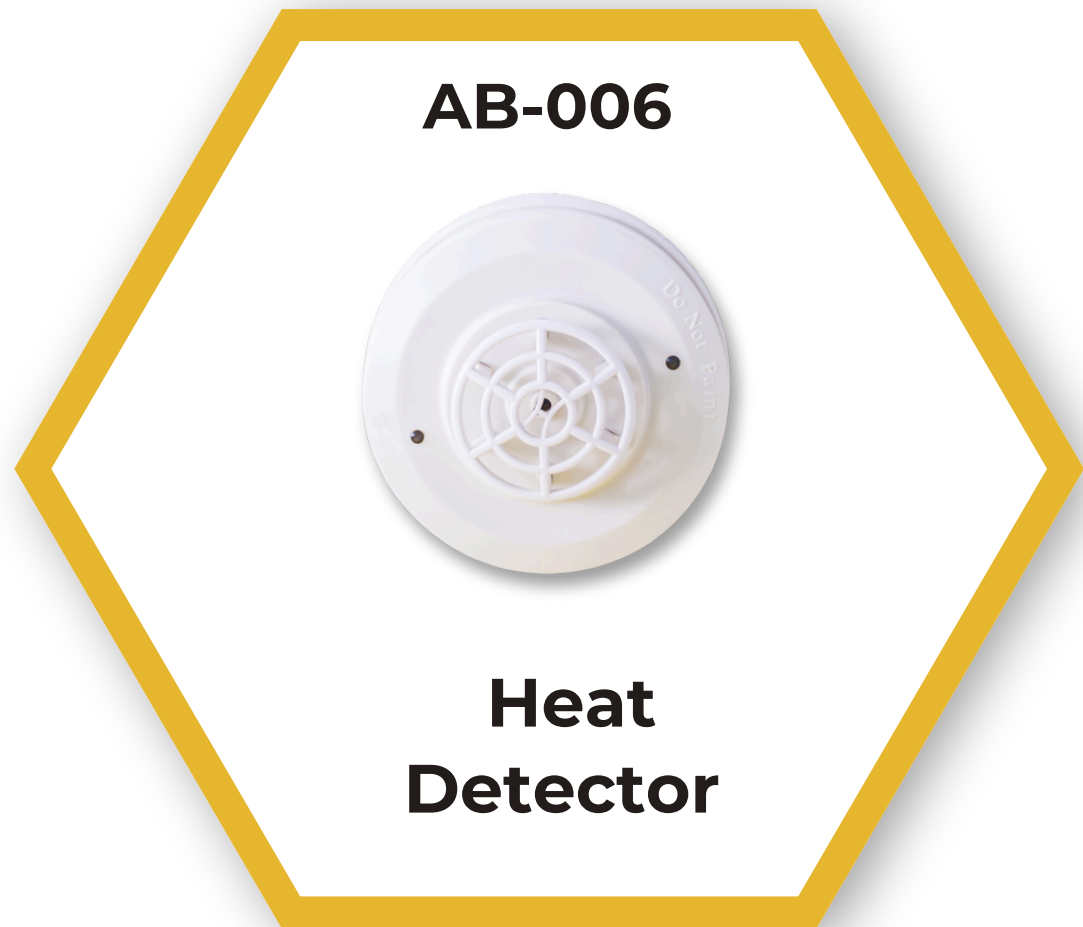
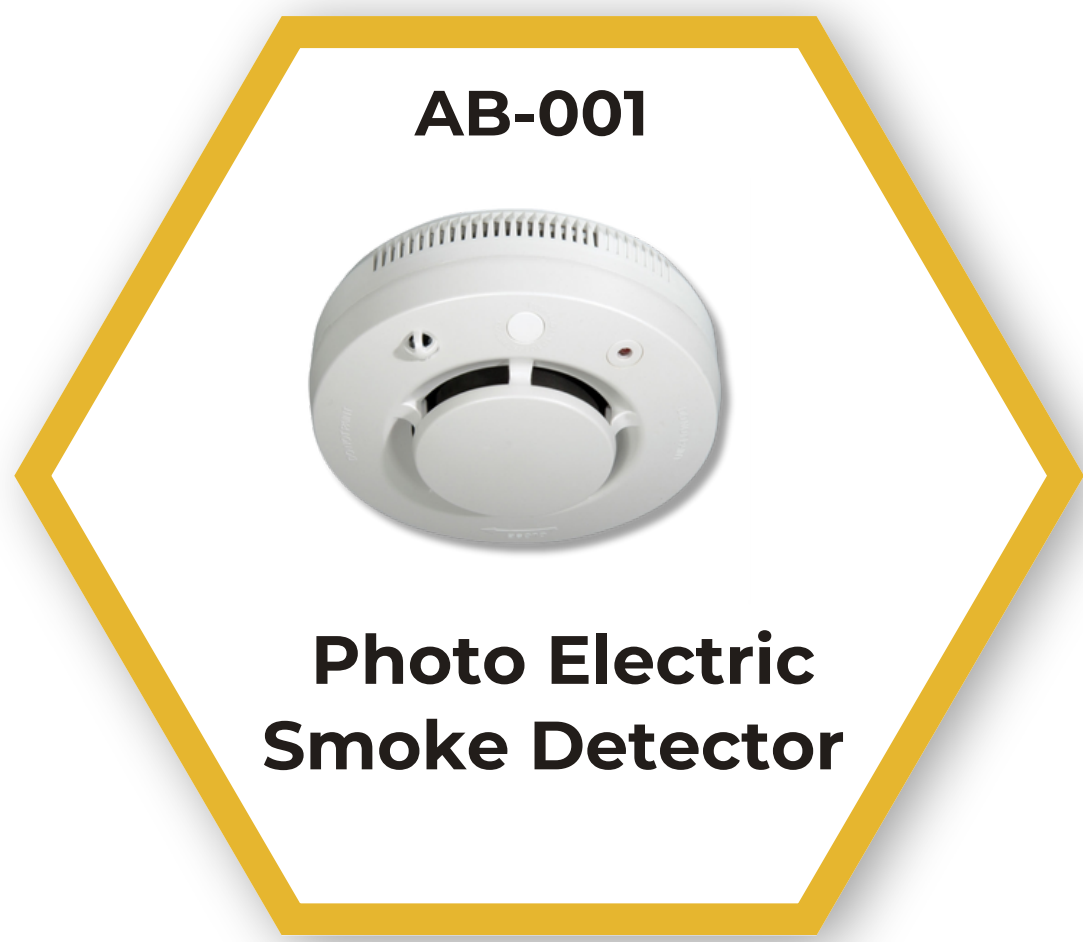

Addressable Fire Alarm Panel

An Addressable Fire Alarm Panel is an advanced system that individually monitors and controls fire detection devices, providing precise location details of alarms or faults. It enhances response time, reduces false alarms, and allows flexible programming, making it ideal for large buildings, commercial spaces, and complex fire safety systems.



Conventional Fire Alarm Control Panel

A Conventional Fire Alarm Control Panel divides a building into detection zones, each with multiple devices. When activated, it indicates the zone but not the exact device. It is cost-effective, simple to install, and ideal for small to medium-sized buildings where pinpoint accuracy is less critical but reliable fire detection is needed.

MODULE

Input Module / Monitor Module Output Module / Control Module Single Unit Input/Output Module Mini Zone Input/Output Modules Relay Modules, Loop Isolation Module



BASES

Detector Base
Sounder/Beacon Base
Wall Mount Base
Ceiling Mount Base
Outdoor Mount Base
Horn Strobe Mount Base



SUPPRESSION SYSTEM

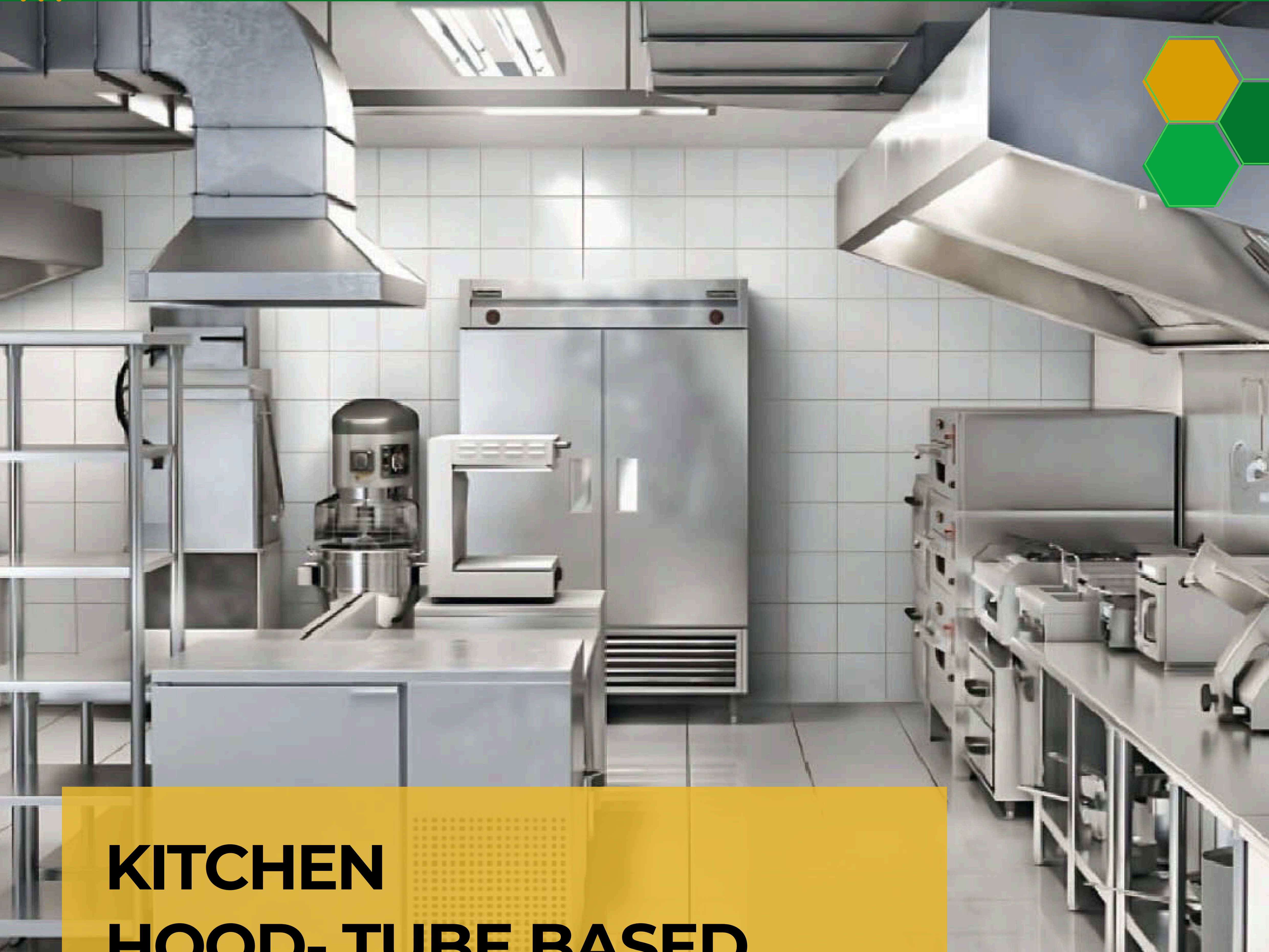

KITCHEN HOOD- TUBE BASED SUPPRESSION SYSTEM

Kitchens tend to use large quantities of hot fat and oil for the preparation of food. These fats and oils pose a particularly high fire risk. Most fires in kitchens start in deep fryers, frying pans and grilling plates, Burners with defective overheating protection. Fat self-ignites at a temperature of 350°C. which is easily reached, and fat fires tend to spread very quickly



Electrical Panels

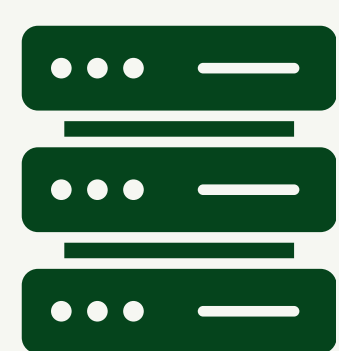

Server Rocks

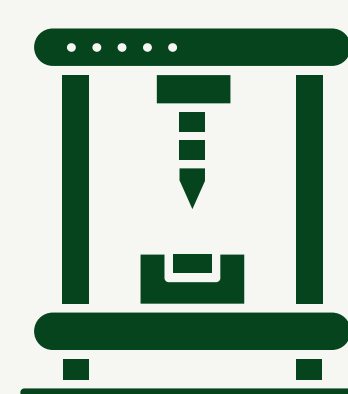

CNC Machine

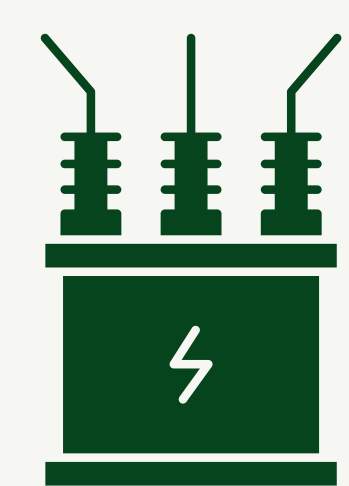

Dry Transformer

Surveillance System

AHD/IP Network Camera



Dome AHD/IP Camera

A Dome AHD/IP Camera is a high-definition surveillance camera designed for indoor or outdoor security. It features a dome-shaped housing for discreet monitoring and protection against vandalism. AHD (Analog High Definition) models transmit HD video over coaxial cables, while IP cameras use network connections for remote access and advanced features like motion detection, night vision, and two-way audio.

Varifocal IR Dome AHD/IP Camera

A Varifocal IR Dome AHD/IP Camera is a high-definition security camera with an adjustable focal length, allowing flexible zoom and focus for precise monitoring. Its infrared (IR) LEDs provide superior night vision, ensuring clear footage in low-light conditions. AHD models transmit HD video over coaxial cables, while IP versions offer network connectivity for remote access, motion detection, and smart analytics. Ideal for indoor and outdoor surveillance.



Megapixel Mini PTZ AHD/IP Camera

A Megapixel Mini PTZ AHD/IP Camera is a compact yet powerful security camera with pan, tilt, and zoom (PTZ) capabilities for flexible monitoring. It delivers high-resolution video, ensuring clear details for surveillance. AHD models transmit HD video over coaxial cables, while IP versions enable remote access, motion detection, and smart analytics. Its small size makes it ideal for discreet indoor and outdoor security applications.

IR Weatherproof AHD/IP Camera

An IR Weatherproof AHD/IP Camera is a high-definition security camera designed for outdoor surveillance in harsh weather conditions. Its infrared (IR) LEDs ensure clear night vision, while the weatherproof housing protects against rain, dust, and extreme temperatures. AHD models transmit HD video over coaxial cables, while IP versions offer network connectivity for remote access, motion detection, and smart analytics. Ideal for reliable 24/7 security.



Surveillance System

HD DVR/NVR

AHD DVR Digital Video Recorder

Support AHD real-time encoding;
Support VGA, HDMI HD output;
Support XM Cloud technology
Support various mobile monitoring: (IOS, Android)
Support multiple web browsers (IE, Chrome)

Video input: 4CH AHD/8CH BNC/16CH BNC;
H.264 High Profile compression algorithm
1080P 25/30fps, 1080P 12fps or 720P 25/30fps Video Recorder
Up to 500meters transmission distance
Support 1 SATA HDD, Up to 4TB
Support Audio Signal IO Smart Video Analysis;
Support Remote Monitoring
Support manual, time based, alarm and motion based recording:
Can trigger snapshot on alarm triggering
Fixed DDNS;
Support CMS
Support PTZ Control, key button, remote Controller, Mouse Control



ADVR-3000

ANVR-6800



NVR Network Video Recorder

An NVR (Network Video Recorder) is a digital surveillance system that records and manages video footage from IP cameras over a network. Unlike DVRs, which process video at the recorder, NVRs receive and store digital video directly from cameras, ensuring high-resolution recording and remote access. They support multiple channels, motion detection, and smart analytics, enhancing security monitoring. With features like cloud storage, HDMI output, and RAID backup, NVRs provide scalable and efficient video management for homes, businesses, and large-scale surveillance systems. Compatible with PoE (Power over Ethernet) for simplified installation, they ensure seamless integration with modern security setups.

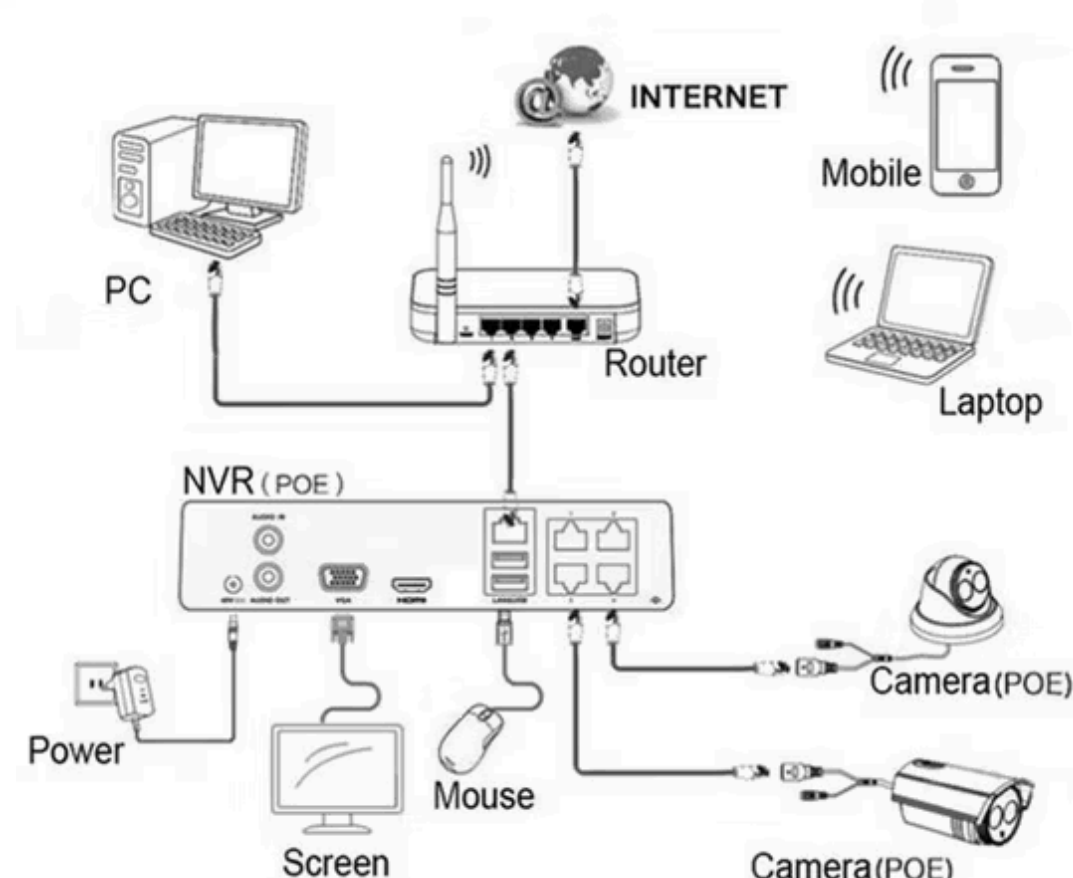

Smart Lighting System

TYPE OF SWITCHES



RETROFIT

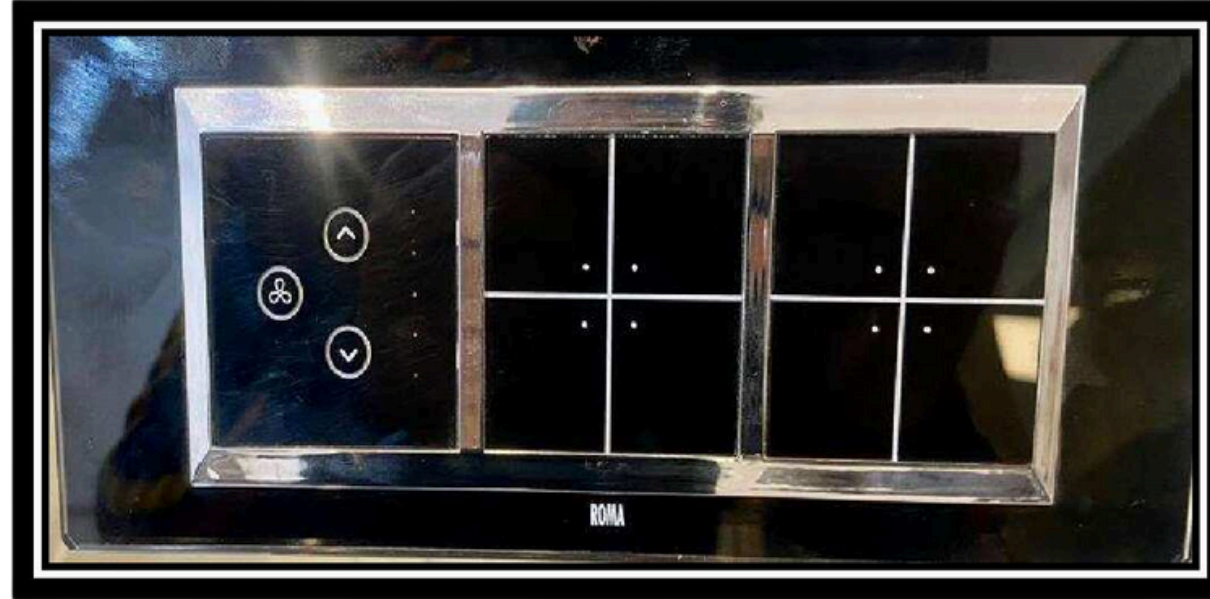

TOUCH SWITCH



TOUCH PLATE

TYPE OF TOUCH PLATES

Touch plates are customizable and made to order, ensuring a perfect fit for specific needs with tailored designs, materials, and functionalities.

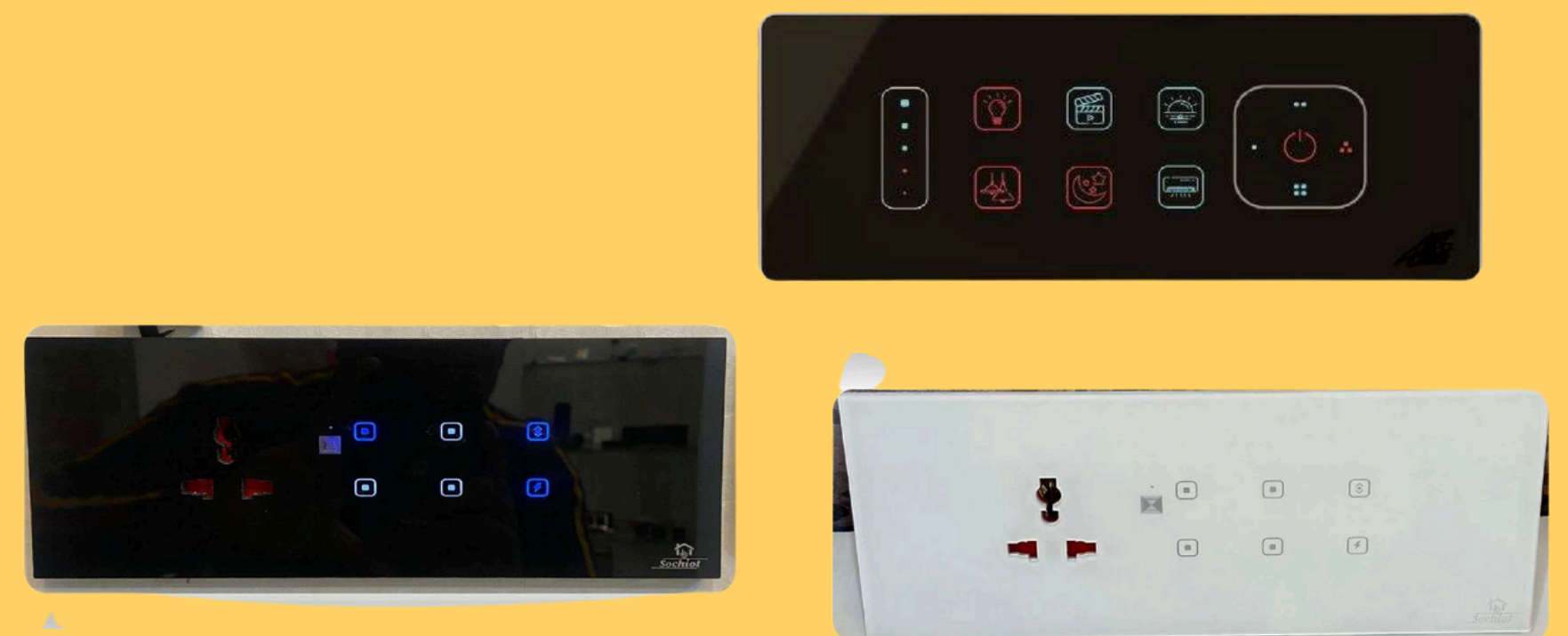

TYPE OF MOTION SENSOR

Motion Sensor are of Two Type

- PIR Motion Sensor
- Radar Motion sensor

Motion Sensor are used in following area

- Corridors
- Balconies
- Staircase
- Washroom
- Parking Lot

Motion Sensor sense the motion of human body with different technologies as mentioned above. In case anyone is not in room /space it automatically turn off the Lights and in case of any movement it Switch on the light. This Saves Lot of Electricity Bills



RADAR SENSOR



PIR MOTION SENSOR



INVISIBLE RADAR SENSOR

Home Automation System

GSM Based Wireless Security System



A GSM-based wireless security system is an advanced security solution that uses Global System for Mobile Communications (GSM) technology to monitor and protect homes, offices, or other premises. It integrates sensors (motion, door, gas, fire, etc.) with a microcontroller, which processes signals and triggers alerts. When unauthorized access or hazards are detected, the system sends SMS alerts or calls to predefined numbers via a GSM module. This system offers real-time, remote monitoring, is cost-effective, scalable, and reliable, making it ideal for security automation.

GSM Based Wireless touch Keypad System

The GSM-based wireless touch keypad system offers secure and convenient access control with real-time alerts via mobile networks. Featuring a sleek touch interface, it enables effortless entry while ensuring enhanced security. With remote access, motion detection, and instant notifications, it provides seamless protection for homes and businesses. Its wireless design allows easy installation, and reliable GSM connectivity ensures continuous operation, even in remote locations.



Biometric Access Control System



DIGITAL Glass Door Lock

Features:

- Material: zinc Alloy
- Access solution: ngerprint, RFID card, password , Mechanical Key, Mobile App
- Scramble Pin code – Anti peek card users 100, ngerprint +card +password, power supply:4.5v-6.5v (4pcs AA battery)
- Touching Screen design – fashion and durable
- Intelligent voice navigation is easy for lock setting secure latch can protect from any break in attempts.
- 5v USB Interface

TYPE OF DOOR BELLS

Door Bells are of Two Type

1. Battery Powered 2. Supply Powered

When anyone is on the Main gate he Will press the Bell and you will get notification on the mobile.

After Pressing the Notification you can see who is on the Door and you can also talk to him and even can take photo of Him



TYPE OF DOOR LOCKS

We have range of Door Locks

- Wooden Door Lock
- Glass Door Lock
- EM latch Lock
- Drawer Lock

These Locks can be opened through Following mechanism

- Finger Print
- RFID Card
- Passcode
- OTP
- SOCHIOR APP (through wifi Dongle for outside)
- Manual Keys



Automatic Gates + Turnstiles



BOOM BARRIER/GATE TOLL/PARKING GATES

Boom barriers control access in estates, parking, and tolls with a four-bar mechanism, photoelectric sensors, overheat protection, and a waterproof design.



AUTOMATIC SLIDING GATE OPERATOR

The automatic sliding gate operator provides smooth, secure, and efficient gate movement with remote control, durable construction, and reliable performance for any entrance.



AUTOMATIC SWING GATE SYSTEM

The automatic swing gate system ensures secure, hands-free access with smooth motion, durable construction, and smart control, ideal for residential and commercial use.



AUTOMATIC SLIDING DOOR SYSTEM

The automatic sliding door system offers smooth, hands-free entry with motion sensors, quiet operation, and a sleek design, ideal for commercial and residential spaces.



VERTICAL TYPES TRIPOD TURNSTILE

Vertical tripod turnstiles provide controlled access with a compact design, durable build, and smooth operation, ideal for security in various entry points.



FLAP BARRIER TURNSTILE

Flap barrier turnstiles provide secure access control with fast, smooth operation. Equipped with sensors and a durable design, they ensure efficient, reliable entry management in various environments.

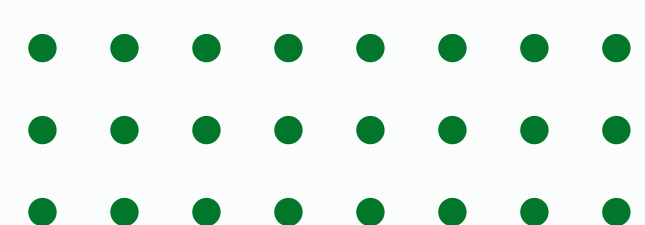

Metal Detector

Portable DOOR FRAME
METAL DETECTOR
(WALK-THROUGH TYPE)

A-PDF01



Wooden DOOR FRAME
METAL DETECTOR
(WALK-THROUGH TYPE)

A-WDM01



6- Zone DOOR FRAME
METAL DETECTOR
(WALK-THROUGH TYPE)

A-LDF06

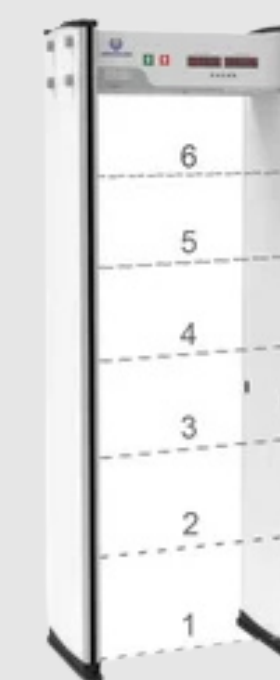

14-Zone DOOR FRAME
METAL DETECTOR
(WALK-THROUGH TYPE)

A-DF14



24-Zone DOOR FRAME
METAL DETECTOR
(WALK-THROUGH TYPE)

A-DF24

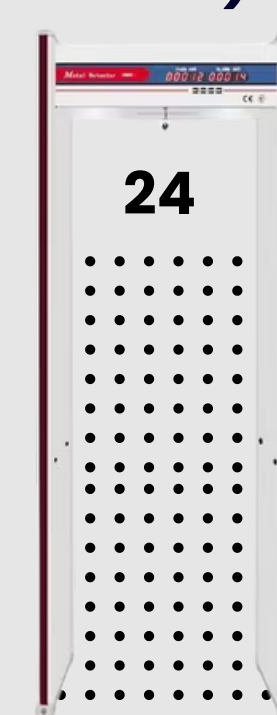

Hand Held Metal Detector

A Hand-Held Metal Detector is a portable security device used to detect metal objects on a person or within items. It operates using electromagnetic fields to sense metallic objects, alerting the user via sound, vibration, or light indicators. Commonly used in security screenings at airports, public events, and law enforcement, it helps detect concealed weapons, knives, and other metal objects. Lightweight and battery-operated, it ensures quick, non-invasive inspections. Advanced models offer adjustable sensitivity, allowing detection of both small and large metal objects. Durable and easy to use, hand-held metal detectors enhance security and prevent unauthorized metal items from entering restricted areas.

PA & EPABX SYSTEM

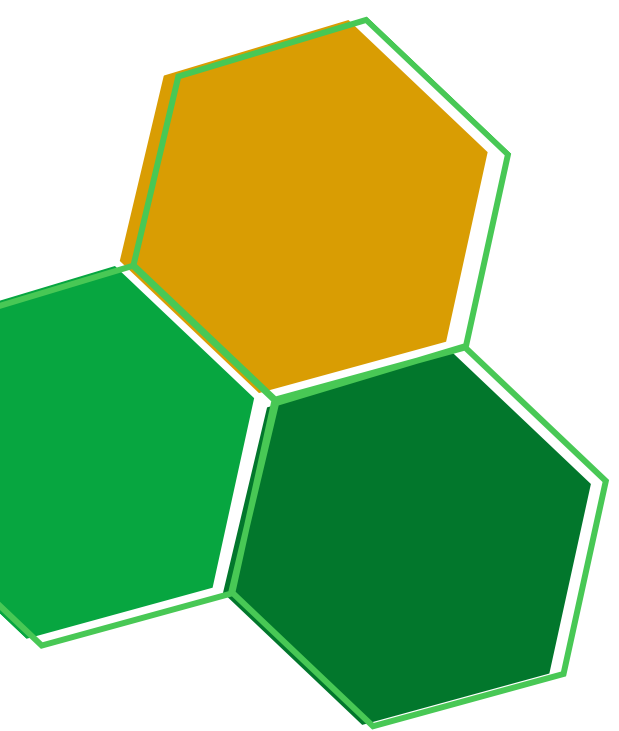
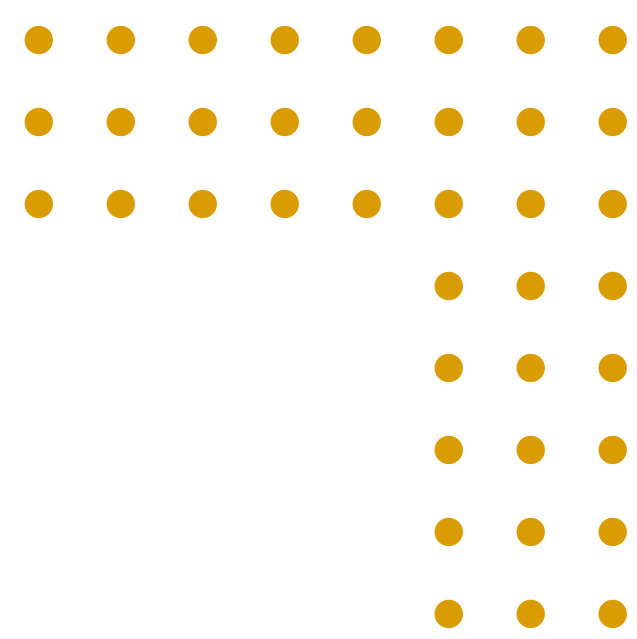

PA SYSTEM (PUBLIC ADDRESSABLE SYSTEM)

ABROL is specializes in Audio Products & System. The Product lines include PA System, Mixer, Amplifiers, Power Amplifiers, Ceiling Speakers, Column Speaker, Wall mount Speakers, Horn Speaker, in Wall Speaker, and multi-room audio System and Microphones, Mixers, Controller, Wireless Audio system, Conference System.

Range of Products in which we are dealing,

CENTRAL PAGING AND EVACUATION SYSTEM
WITH BACKGROUND MUSIC CONFERENCE
SYSTEMS BUSINESS MUSIC SYSTEMS PUBLIC
ADDRESS SYSTEMS/EQUIPMENTS PRO AUDIO
PRODUCTS WIRELESS MICROPHONES 2 WAY
TALK BACK SYSTEMS DJ SYSTEMS

EPABX & INTERCOM SOLUTIONS- [EPABX] ELECTRONIC PRIVATE AUTOMATIC BRANCH EXCHANGE

A private branch exchange (PBX) is a telephone exchange that serves a particular business or office, as opposed to one that a common carrier or telephone company operates for many businesses or for the general public. PBXs are also referred to as PABX -private automatic branch exchange and EPABX.

The feature of a call transferring and forwarding is another area enabling mobility of the users. Autoconferencing and automatic redialling of numbers found engaged on the first trial are some of other advancements in the features of the EPBAX.

System Capacity

64 & More Extension Ports
64ch & More Trunk Ports

System Features

Automatic ISDN Setting (BRI)
Automatic Route Selection (ARS)
PC Console/PC Phone
OR Least Cost Routing (LCR)
PC Programming
VIP-Call
Visual Caller ID
Digital eXtra Device Port (XDP)
Hands-free Operation

DECT Features

Automatic Handover
Wireless XDP Parallel Mode

ISDN Service Features

Calling Line Identification
Presentation (CLIP)
Direct Dialling Inward (DDI)
ISDN Call Forward (CFU/CFNR/CFB)
Multiple Subscriber Numbers (MSN)

Networking Features

ARS with VoIP
QSIG Connection
VoIP Network (Built-in IP-GW)

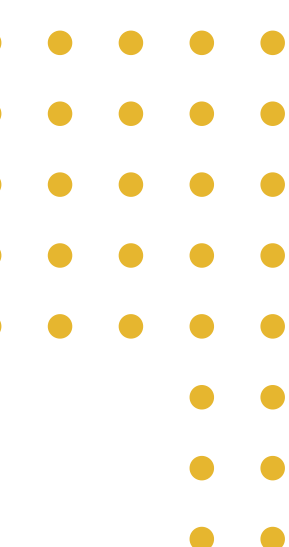
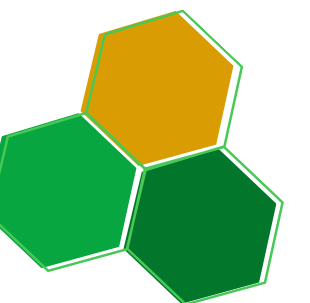

PERSONAL PROTECTION KIT FOR DAILY INDUSTRIAL USE SET-007

This kit is equipped with all necessary protective wears that are required for ensuring the minimal safety of the personnel at work and protect them from accident & injuries.

This kit is very suitable in almost all industries including construction & civil works..



**Safety Helmet
(1pc)**



**Safety Goggles
(1pc)**



**Reflective Vest
(1pc)**



**Safety Shoe
IS15298*PII (1pr)**



**Safety Dotted
Gloves (1pr)**



**Ear Plug
(1set)**



**N95 Mask
(1pc)**



**Kit Bag
(1pc)**

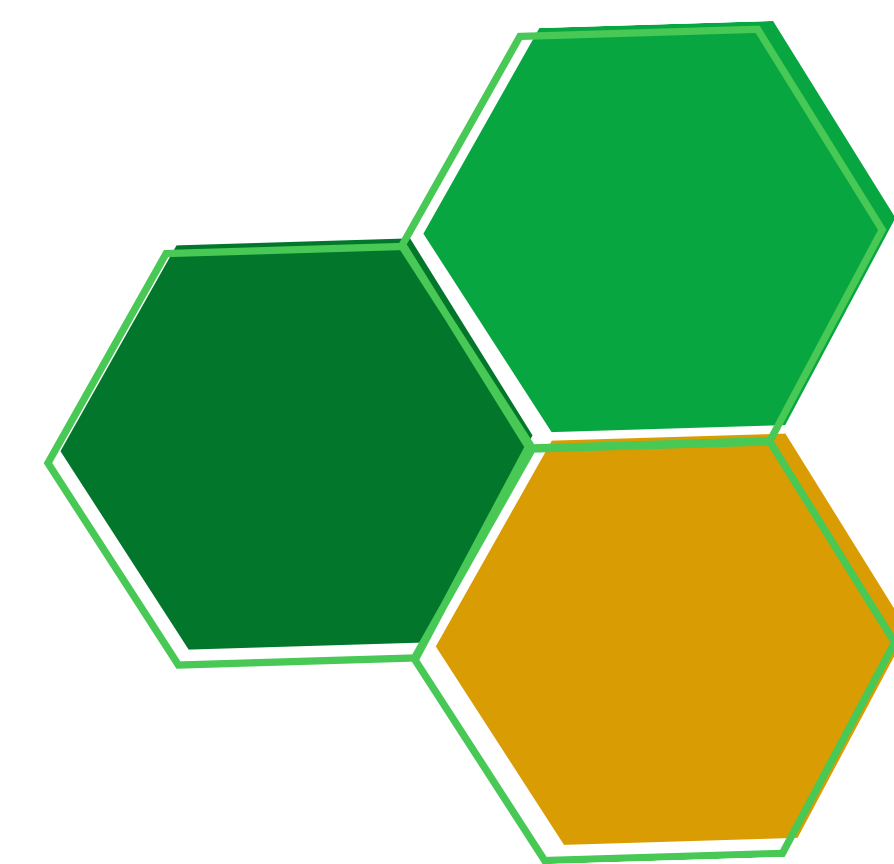
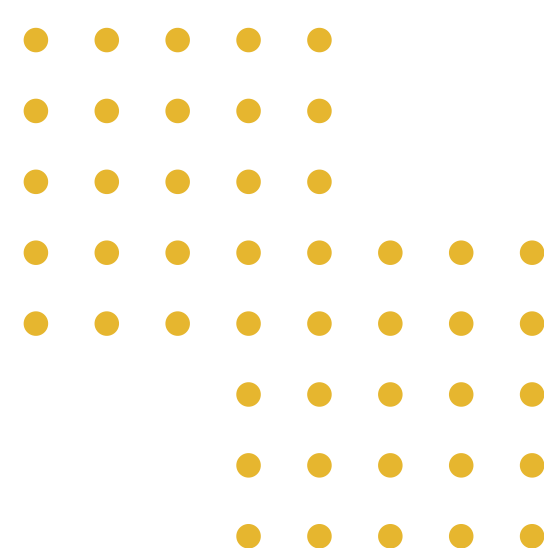

FEW OF OUR ESTEEM CLIENTS

ABR have very good and wide Dealer network (Distribution of material through our dealer) in all over India i.e. Punjab, Haryana, Himachal Pradesh, Uttaranchal, Rajasthan, Uttar Pradesh, Gujarat.

Some of our clients are as follows:

Chandigarh Police	Metro Institute of Medical Science Pvt. Ltd., Noida
Government of India (Provided Surveillance to Prime Minister)	Oasis Immigration & Consultants Pvt. Ltd., Chandigarh
Shimla Police -Ridge and Mall Road, Himachal Pradesh	PostGraguateInstitueofMedicalEducationandResearch,Cha ndigarh(PGI)
Punjab Police (Head Quarter),Chandigarh	CLAAS India Private ltd., Morinda (Pb.)
BSF (Western Command) Chandigarh	Delhi Public School, Chandigarh (DPS)
Punjab University, Chandigarh	CADILA Healthcare ltd., Baddi (HP.) ZYDUS
Judicial Academy Chandigarh	United Biscuit Ltd., KalaAmb
Adiya Birla Group	IVY Hospital, Mohali
Jindal Industries	Malwa Indusrties Ltd., Ludhiana
Johnson and Johnson Ltd., Baddi	Indian Oil Corporation, Chandigarh
IDS Ltd., Mohali	Mahindra & Mahindra, Ltd., Haridwar
USV Pharma, Baddi	Parle Biscuit Pvt. Ltd., Neemrana
Hero Moto Corps Limited, Sidcul - Haridwar	Baba Ramdev Patangali, Haridwar
Mahle Filters Pvt. Ltd., Parwanoo (ANAND Group)	International Fresh Farm Mega Food Park Ltd.,CHD - Sangrur, Channo, Fazilka Sites
GBP Group, Zirakpur, Punjab	Sushma Build tech Ltd., Zirakpur
Jones Lang LaSalle Building operations Pvt Ltd, Gurgaon	Motia Group; Royal Motia, Zirakpur
Bollywood Height, Punjab	Jal Vayu Towers, Mohali, (JVT)
Janta Land Promotors Ltd., Mohali, Pb. (JLPL)	Mankind Pharma Ltd., Sirmour, HP
Maya Garden, Zirakpur, Punjab	Tirupati Life sciences pharma Pvt. Ltd., Kala-amb, HP
EXIM Bank, Elante, Chandigarh	Punjab State E- Governer Society
Sungro Seeds Ltd., Delhi	Trackon Couriers pvt. Ltd, Chandigarh
Satluj Spintex limited, Mansa	Nandos, Sector35, Chandigarh
Modulus Pvt. Ltd., Parwanoo.	The Majestic Hotel, Mohali
MCM DAV School, Chandigarh	Affy Pharma Pvt. Ltd., Baddi
Talwar Dairies, Chandigarh	Monad profiles, Panchkula
Poddar Tyres Ltd., Ludhiana (Bedrock)	Shehensha Restaurant, Chandigarh

Punjab Vigilance Department, Chandigarh	Vishav Manav Ruhani Kendra, Baddi
Zavor Jeweller, Sector-22, Chandigarh (ManyotherJwellersinTricity)	Competent Synergies India Pvt. Ltd., Chandigarh & Mohali
Emerging India Pvt., Ltd., Chandigarh	Raffles Millennium fashion School, Chandigarh
Shinmar Industries, Mohali	Unisex Solutions, Mohali
Competent Synergies Pvt. Ltd., CHD Mohali	Modulus Pvt. Ltd., Parwanoo.
AIRAWAT ARMY Canteen, Patiala	Sky Net Tower, Zirakpur
IDS Infotech Limited, Mohali	Mayfair Apartment, Mohali
Competent House, Chandigarh	A. R. Electrical, Haridwar(U.K.)
CII, Chandigarh	Revati Print-O-Packs Ltd., Haridwar (U.K.)
Shahid Udham Singh Collage, Tangori	Shivalik Public School, Chandigarh & Nawasheher
J.B.J. Internationals. Ltd., Baddi	SnowPack, Bhadrabad, Haridwar(U.K.)
J.B.J. Perfumers Pvt. Ltd., Baddi	HQ Lamps Ltd., Haridwar(U.K.)
Vaishnabi Cosmetics, Baddi	Goel Lighting ltd., Haridwar (U.K.)
Vishwas publication, Mohali	INDIA Meditech ltd., Haridwar (U.K.)
Mohan Fibers, Derabassi	Garg Motors, Yamunanagar
Amba Polytechnic, Derabassi	Hero Moto Corps Limited, Neemrana(Rj)
Vishwas Pharmaceuticals, Mohali	Unitech Enterprises, Mohali
Cambay-Five star Hotel Udaipur	AP Induction, Mohali
Gupta Associates, Chd.	Bhogal Industries, Mohali
Chandigarh almost all Guest houses.	Azad Printers, Chandigarh
TNG, Mohali	Prince offset Printers, Chandigarh
Samsung, Mohali	Shivalik Public School, Mohali
G.K. Traders, Mohali	Sitson India Pvt. Ltd., Pune
Geekan Designes, Baddi	Laxshmi Energy & Foods Ltd., Khamanon
Gayatari Industries, Baddi	Aakaar Designs, Chandigarh
Dee & Vee Associates, Mohali	Atma Ram Jewellers, Panchkula
Bhai Matadaas society, Panchkula	Mind Tree School, Kharar
Moti Mahal (Zaika), Chandigarh	Zee Litra School, Derabasi
Mikado Group, Panchkula	Ethos Limited, Chandigarh
Sialkot House, Ambala	Raj & Associates, Chandigarh
Raj Interiors, Chandigarh	New Panipat Handloom, Haridwar(U.K.)
R.K. Garg, Ambala	Bikanerwala, Haridwar
Godrej	Baddi, Himachal Pradesh
Immacule life science	Baddi, Himachal Pradesh
Helios Pharmaceutical	Baddi, Himachal Pradesh
And Many More.....	

CERTIFIED UNDER BELOW ASSOCIATION



Our Recognitions:

When seeking a product development partner for Safety & Security, it's essential to choose one recognized by industry-leading organizations. ABROL takes pride in creating innovative products that have been certified and approved by major organizations in technology and development.



Contact Us

Phone

+91 9915222897

Website

www.abrolgroup.com

Email

sales@abrolgroup.com

